

CS 8311Bi/BCi

*Remote Head
B/W CCD Video Camera*



- *2/3" Hyper HAD CCD Sensor*
- *High Resolution*
- *Random Trigger Shutter (RTS)*
- *Electronic Shutter*
- *Application*
 - **Machine vision**
 - **Factory automation**
 - **Quality control**



Technical Data

Type	CS 8311Bi/BCi
Image sensor	2/3" Hyper HAD CCD Sensor
Active pixel	752 (H) x 582 (V) CCIR 768 (H) x 494 (V) EIA
Pixel size	8.6 (H) x 8.3 (V) μm (CCIR) or 8.4 (H) x 9.8 (V) μm (EIA)
Image Area	6.4 (H) x 4.8 (V) mm
Scanning system	2:1 interlace
Sync system	Internal/External (automatically switched)
Scanning frequency	Horizontal: 15.734 kHz (CCIR), 15.625 kHz (EIA) Vertical: 59.94 Hz (CCIR) / 50Hz (EIA)
Aspect ratio	4:3
Illumination	0.5 Lux (F1.4)
Video output	VS: 1.0V (p_p) / 75 Ohm (either AC or DC coupling is available)
S/N	>56 dB
Gamma correction	0.45 / 1.0 switchable, factory setting 1.0
Electronic Shutter	ON/OFF SW on front panel, shutter selected by SW inside: 1/60, 1/125, 1/250, 1/500, 1/1000, 1/2000, 1/4000, 1/10000s, flickerless
Lens mount	C-Mount
Power supply	DC12V +/-10% / approx 270W
Ambient condition	Temperature: 0°C to 40°C Humidity: 10 to 90%
Dimension	CCU: 29(H) x 44(W) x 64(D)mm, Head: 29(H) x 44(W) x 32.5(D)mm
Weight	CCU: 90g Head: 70g

Dimension

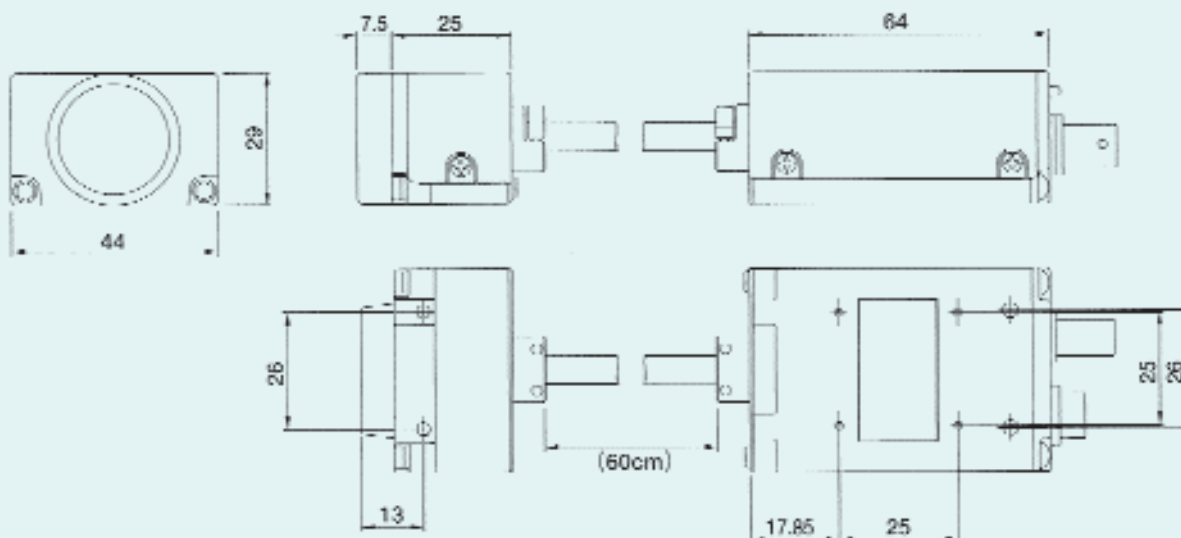

NEW ELECTRONIC TECHNOLOGY Vertriebs-GmbH

Lerchenberg 7 • D 86923 Finning, Germany • Phone: +49(0)88 06 - 92 34-0 • Fax: +49(0)88 06 - 92 34-77

E-mail: info@net-gmbh.com

NET USA, Inc.

3037-45th Street #8 • Highland, IN 46322 • Phone: (219) 934-9042 • Fax: (219) 934-9047

E-mail: netusa@bellsouth.net

www.net-gmbh.com